

## Data sheet LSC1.4S-51

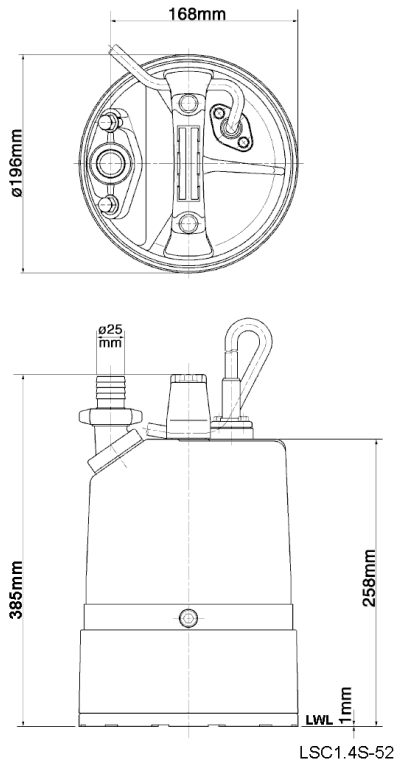

LSC1.4S-52

LWL: Lowest running water level

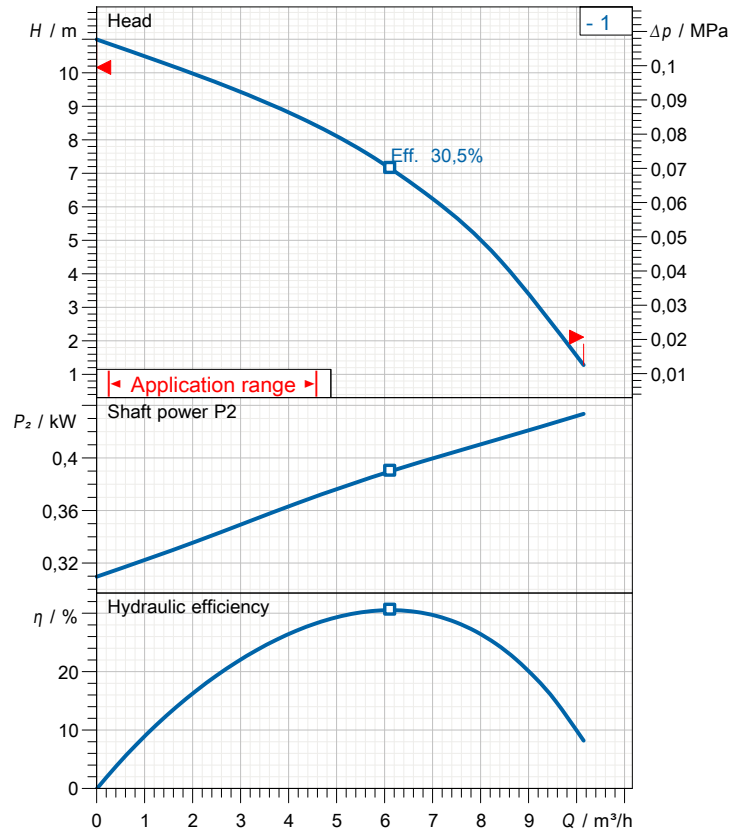

## Specification

Elektrische Tauchpumpe LSC-Serie  
 Degree of protection IP 68  
 Pressure resistance max. 10 m  
 Type of impeller semi-vortex  
 Max. solid handling 6 mm  
 Suitable for:  
 residue water on flat surfaces

## Electric motor

Dry-type submersible induction motor  
 Insulation class E 2Poles 2610 1/min  
 Starting mode  
 Rated voltage 230 V 50 Hz 1~  
 Power uptake 0,59 kW  
 Rated power 0,48 kW  
 Rated current 2,9 A  
 Start current

## Cable

 10m H07RN-F 3Cx1mm<sup>2</sup>

## Motor Protection

Circle thermal protector  
 (snap-action bi-metal device)

## Shaft seal

Double inside mechanical seal in oil bath  
 additional lubrication by oil lifting device  
 Primary seal  
 Silicon carbide on silicon carbide  
 Secondary seal  
 Carbon on ceramic

## Bearings

Shielded ball bearings, maintenance-free

## Materials

Impeller	Urethane rubber
Pump casing	Polypropylene / polyethylene
Motor Frame	Steel plate
Shaft	SUS403 (EN-X6Cr13)

## Discharge size

1" (25mm) hose coupling

## Weight

12 kg (dry weight of the pump only without cable)

# Performance curve

## LSC1.4S-51

Discharge port	DN 25
FördH	11,0 m
Flow	10,1 m³/h
Rated power	0,48 kW
Power input	0,59 kW
Phases	1~
Voltages	230 V
Frequency	50 Hz
Rated current	2,9 A
Starting current	
Number of poles	2
Speed	2610 1/min
Starting mode	
Insulation class	E

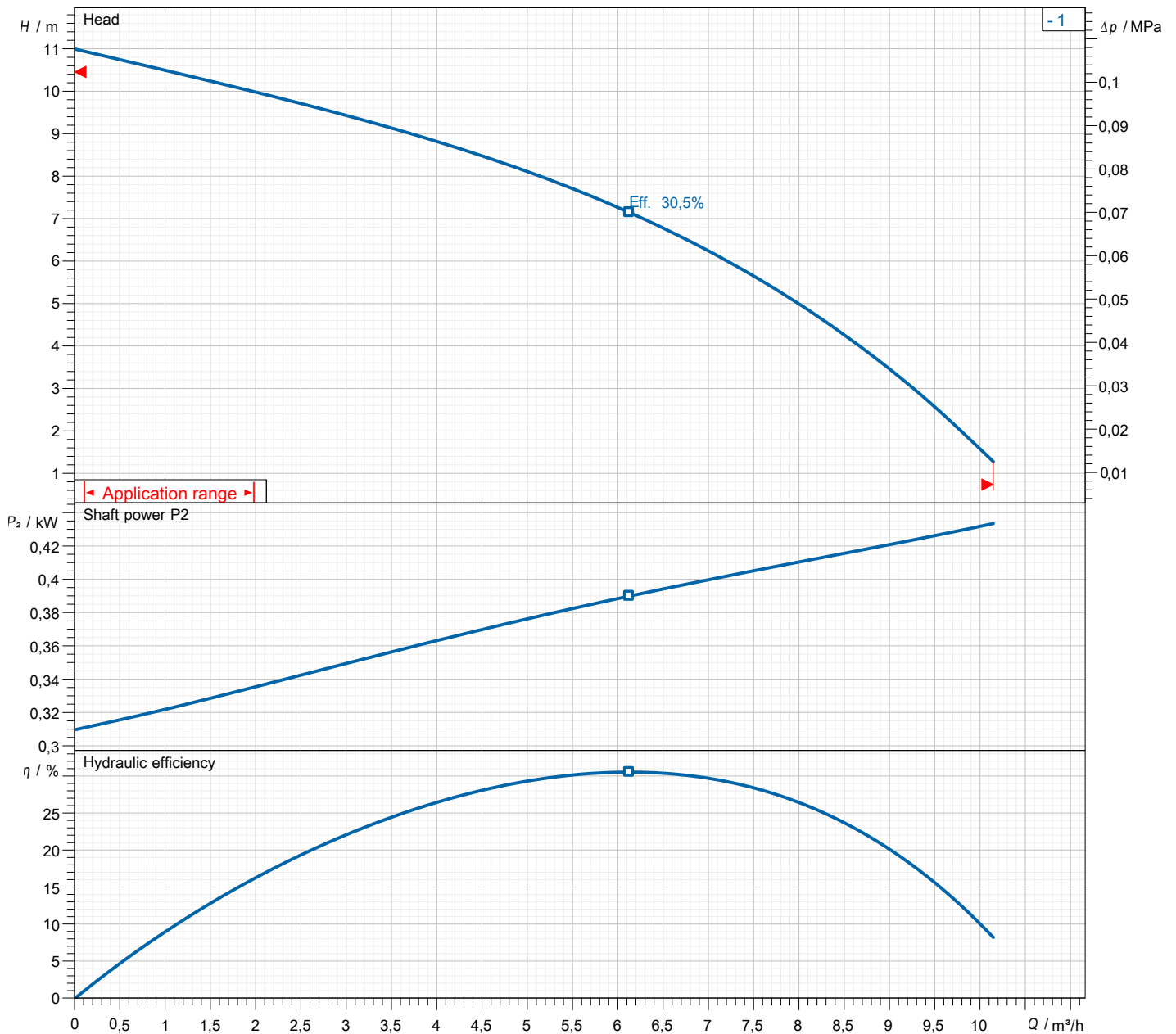

# Dimensions LSC1.4S-51

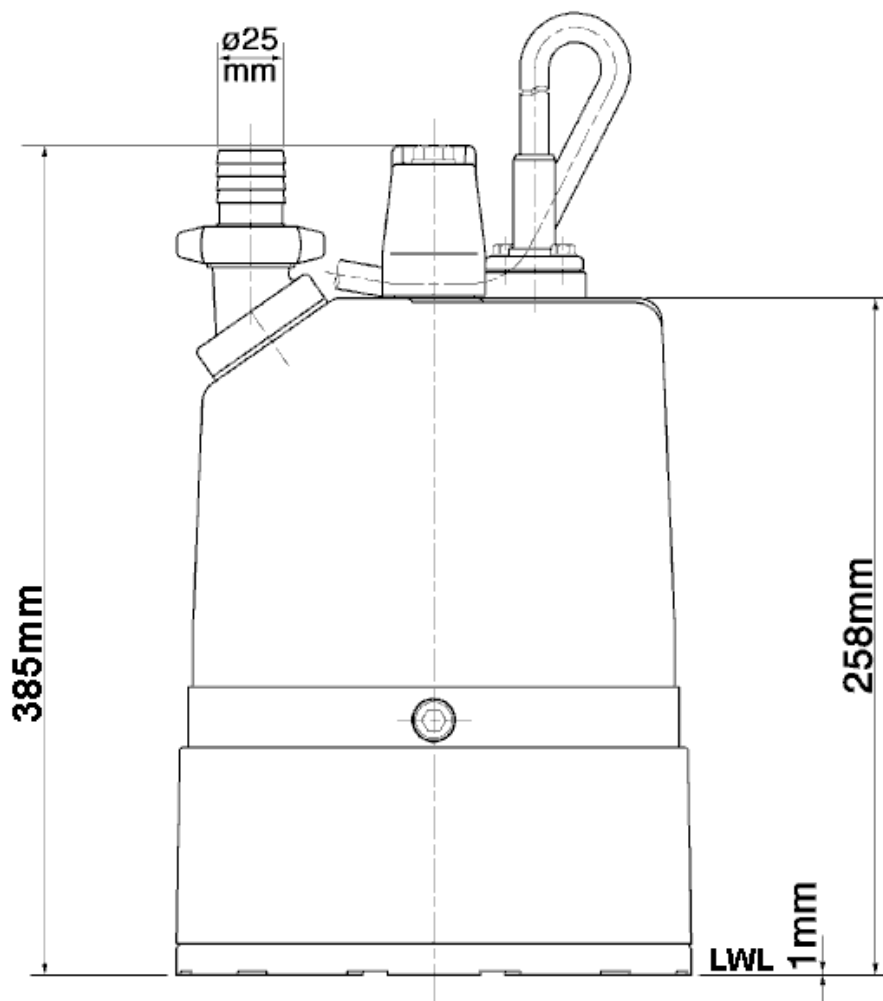
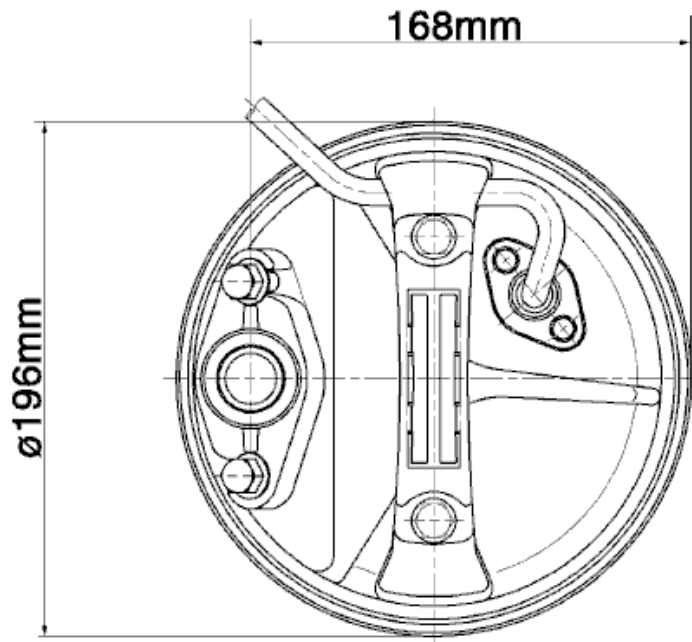

LSC1.4S-52

CWL: Continuous running water level  
LWL: Lowest running water level

# Sectional drawing LSC1.4S-51

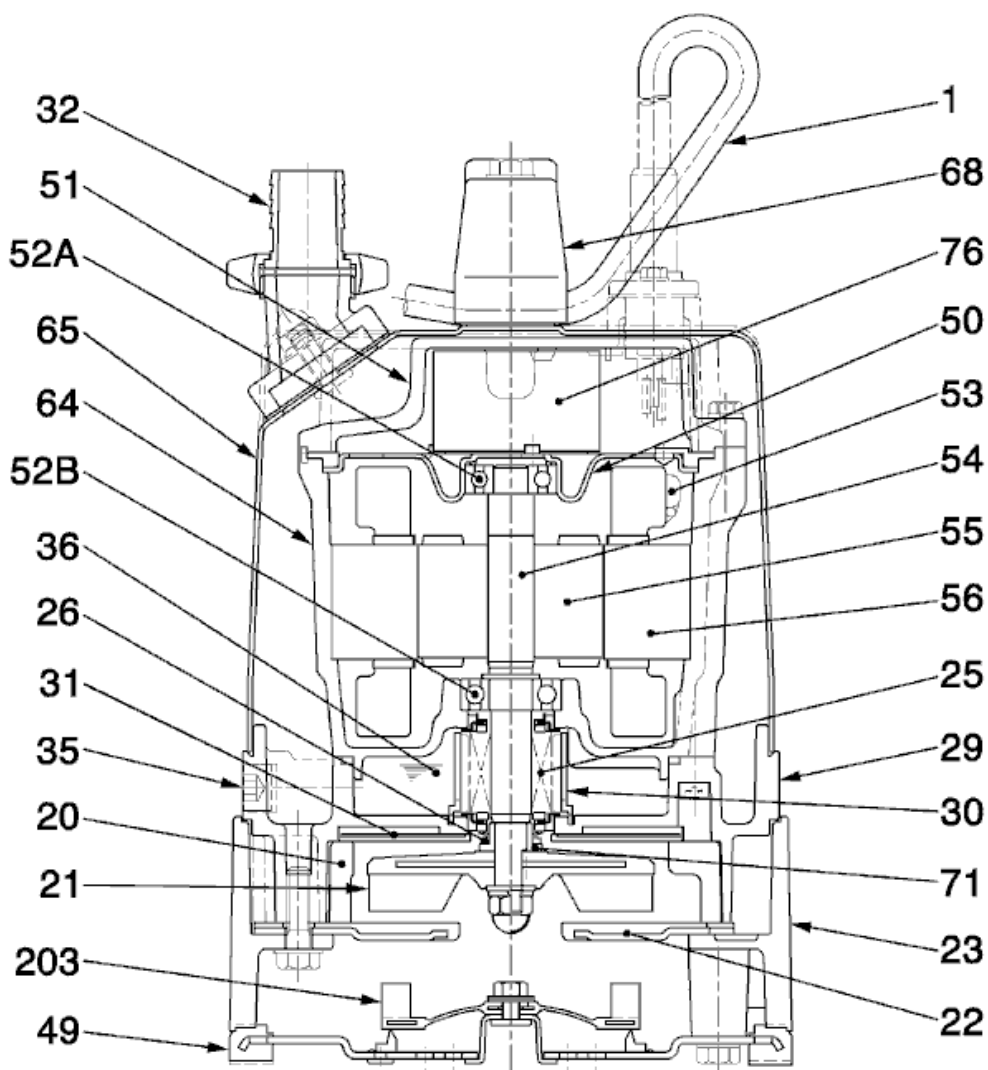

**LSC1.4S-51**

No.	Description	Remark	No.	Description	Remark
1	Cable	H07RN-F	52A	Upper bearing	6201ZZC3
20	Pump casing	Polypropylene / polyethylene	52B	Lower bearing	6202ZZC3
21	Impeller	Urethane rubber	53	Miniature protector	.
22	Suction cover	Steel plate + Urethane rubber	54	Shaft	SUS403 (EN-X6Cr13)
23	Strainer	Aluminium die casting	55	Rotor	.
25	Mechanical seal	Siiziunkarbid, W-14VL	56	Stator	.
26	Oil seal	Butadieneacrylnitrilerubber	64	Motor Frame	Steel plate
29	Oil casing	Aluminium die casting	65	Outer Cover	Aluminium die casting
30	Oil distributor	Plastic	68	Handle	Plastic
31	Attrition plate	Urethane rubber	71	Shaft protection sleeve	SUS304 (EN-X5CrNi18-10)
32	Discharge coupling	Aluminium die casting	76	Condenser	.
35	Oil screw	SUS304 (EN-X5CrNi18-10)	203	Nonreturn valve	Styrenebutadienerubber
36	Lubricant	Turbine oil (ISO VG32)			
49	Bottom Plate	Steelplate + butadieneacrylnitrilerubber			
50	Motor cover	Steel plate			
51	Main cover	Aluminium die casting			